

CSE 390B, Spring 2022

Building Academic Success Through Bottom-Up Computing

Annotation Strategies & Machine Languages

Annotation Strategies, Introduction to Assembly Languages,
Machine Language Specifications, The Hack Assembly Language

Lecture Outline

❖ Annotation Strategies

- The What and How of Annotating Texts

❖ Introduction to Assembly Languages

- Producing Machine Code

❖ Machine Language Specifications

- Operations, Addressing Modes, & Flow Control

❖ The Hack Assembly Language

- Registers, A-Instructions, Symbols, & C-Instructions

Annotating Your Texts

❖ WHAT

Intentionality of interacting with a text to enhance the reader's understanding of, recall of, and reaction to the text



Annotating Your Texts

❖ WHAT

Intentionality of interacting with a text to enhance the reader's understanding of, recall of, and reaction to the text

❖ HOW

- **Highlighting**, underlining or using [brackets] to note key points or ideas



Annotating Your Texts

❖ WHAT

Intentionality of interacting with a text to enhance the reader's understanding of, recall of, and reaction to the text

❖ HOW

- **Highlighting**, underlining or using [brackets] to note key points or ideas
- Circling unfamiliar words or confusing parts of the text



Annotating Your Texts

❖ WHAT

Intentionality of interacting with a text to enhance the reader's understanding of, recall of, and reaction to the text

❖ HOW

- **Highlighting**, underlining or using [brackets] to note key points or ideas
- Circling unfamiliar words or confusing parts of the text
- *Paraphrasing or summarizing passages/chapters/sections*



Annotating Your Texts

❖ WHAT

Intentionality of interacting with a text to enhance the reader's understanding of, recall of, and reaction to the text

❖ HOW

- **Highlighting**, underlining or using [brackets] to note key points or ideas
- **Circling unfamiliar words or confusing parts of the text**
- *Paraphrasing or summarizing passages/chapters/sections*
- **Commenting or reacting to the text** 🤔

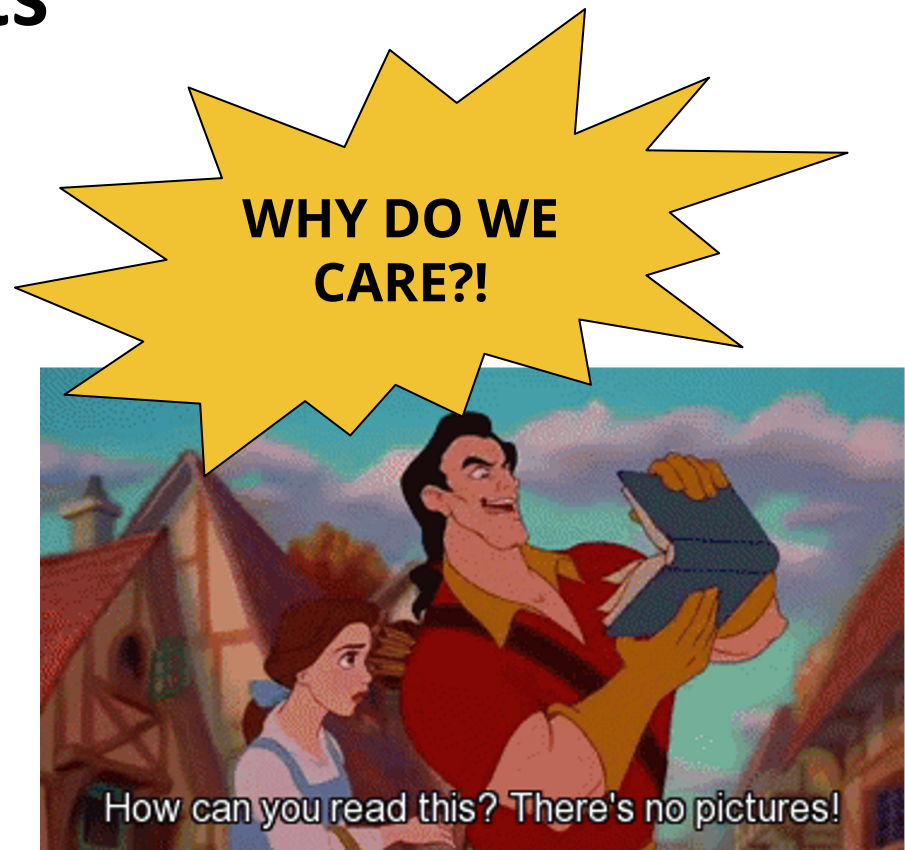

Lecture Outline

- ❖ Annotation Strategies
 - The What and How of Annotating Texts
- ❖ **Introduction to Assembly Languages**
 - **Producing Machine Code**
- ❖ Machine Language Specifications
 - Operations, Addressing Modes, & Flow Control
- ❖ The Hack Assembly Language
 - Registers, A-Instructions, Symbols, & C-Instructions



Vote at <https://pollev.com/cse390b>

Project 4 Check-in

- ❖ Which chips in Project 4 gave or are giving you the most trouble?
- ❖ What skills or concepts have you struggled with most?
 - E.g., certain aspects of HDL, rules of sequential logic, etc.
- ❖ Any other questions, comments, or concerns about anything?

Project 4 Resources

❖ Take advantage of hints in Project 4 readings

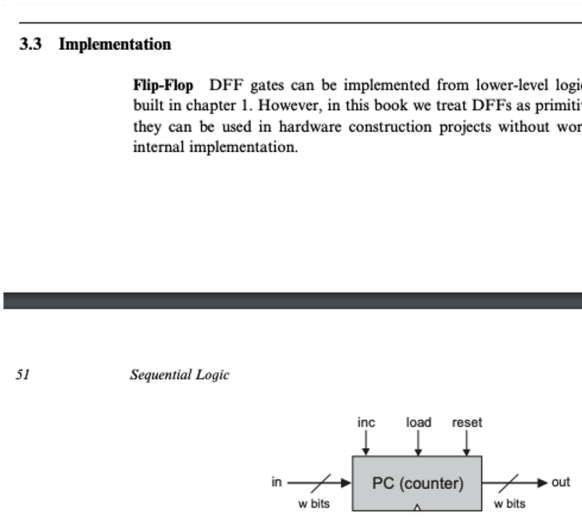

[Chapter 3](#)

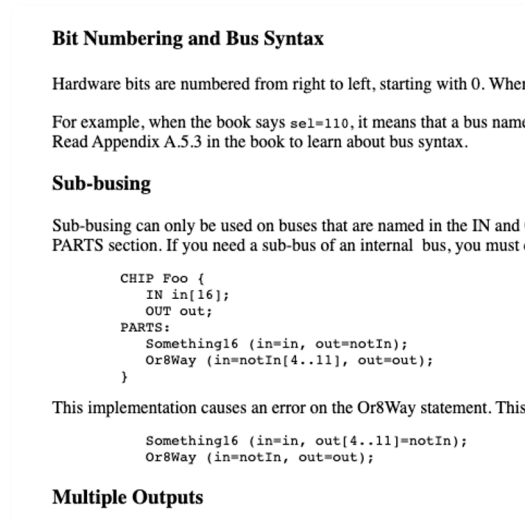

[HDL Survival Guide](#)

❖ Reach out to your classmates and course staff

- Post on the Ed discussion board
- Come to office hours today after lecture



Vote at <https://pollev.com/cse390b>

Which of the following statements about assembly languages and machine code is TRUE?

- A. Assembly languages are translated to binary by a compiler**
- B. Assembly languages were created to provide a more human-readable format for specifying machine code**
- C. Registers are temporary storage locations that are stored in memory**
- D. The Hack computer architecture supports multiplication and division**
- E. We're lost...**

Revisiting The Von Neumann Architecture

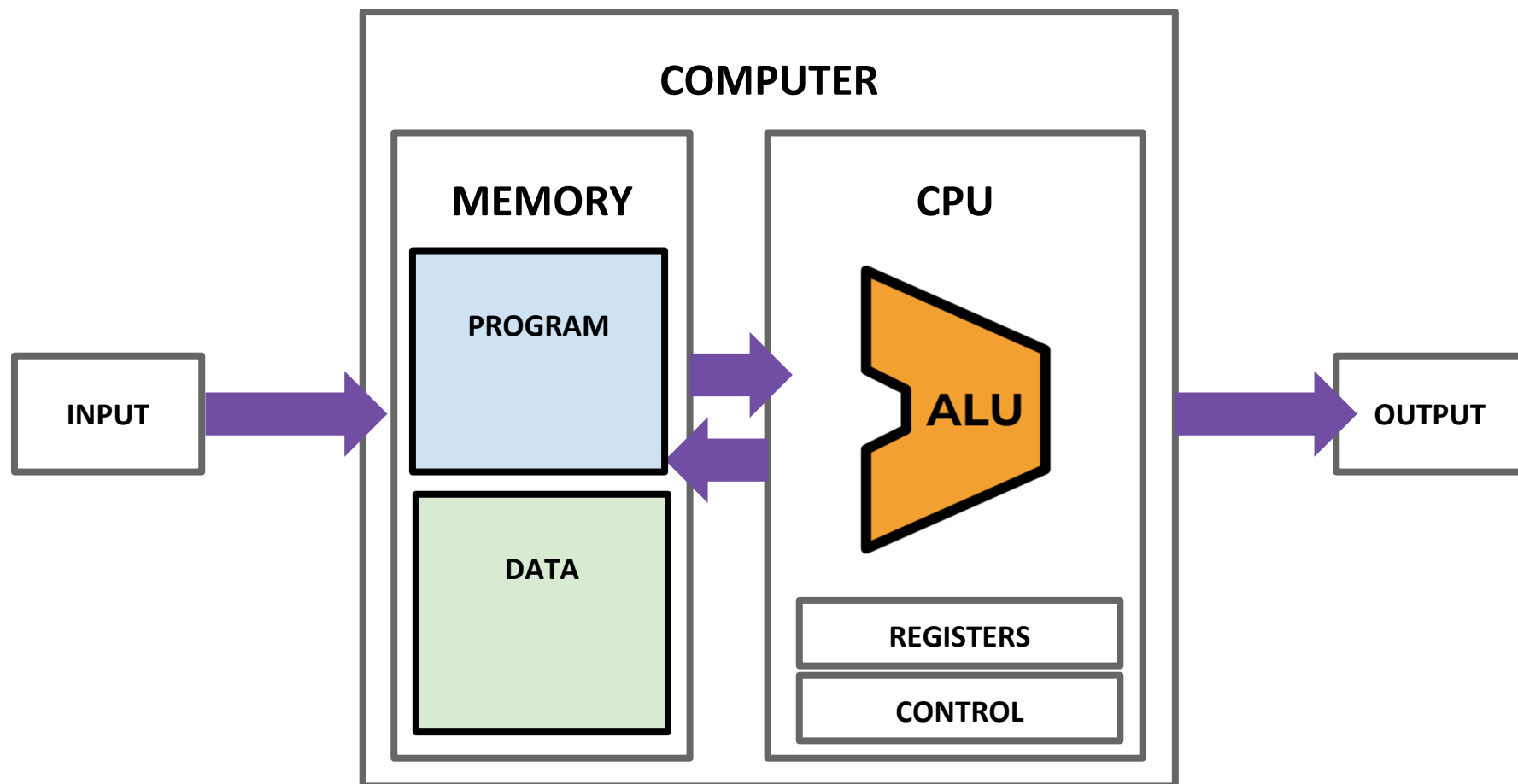

(This picture will get more detailed as we go!)

Machine Code

- ❖ Instructions are stored in memory, so they must be able to be encoded in binary
- ❖ When we refer to **machine code**, we are typically talking about this binary representation of code
- ❖ Each instruction is a sequence of 0s and 1s
 - Our computer / hardware specification is what gives meaning to each part of this sequence
 - “Is this an add or subtract instruction? What are the inputs?”

Storing the Program

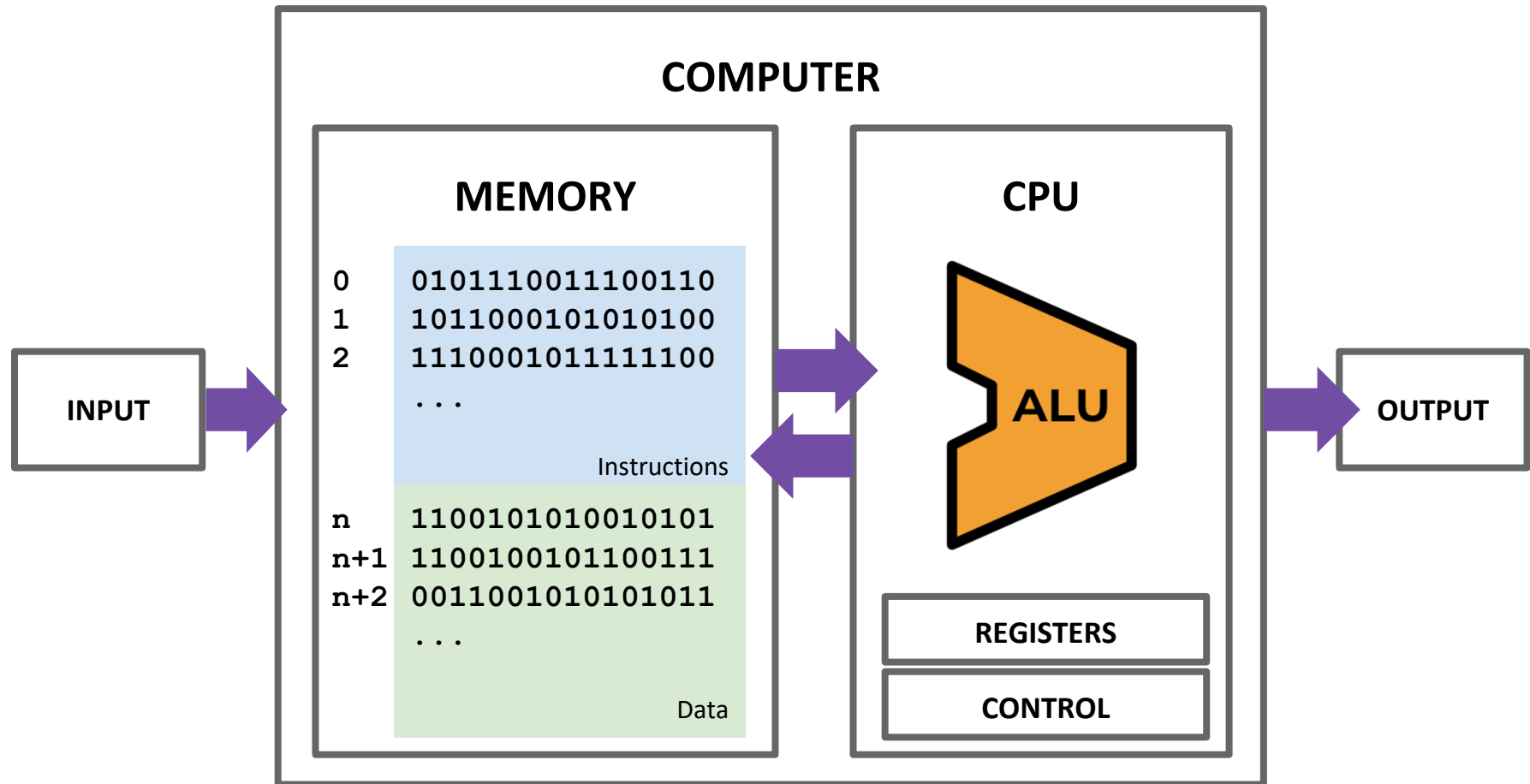

(This picture will get more detailed as we go!)

Assembly Languages

- ❖ Writing code using 0s and 1s is tedious and error prone
- ❖ Assembly languages are a human-readable format of binary instructions that a CPU runs
- ❖ Each human-readable assembly instruction has a corresponding binary machine code instruction
 - Example: `addq reg1, reg2 == 0b1011000101010100`
- ❖ Assembly is often used as an intermediary between a high-level programming language and machine code

Producing Machine Code

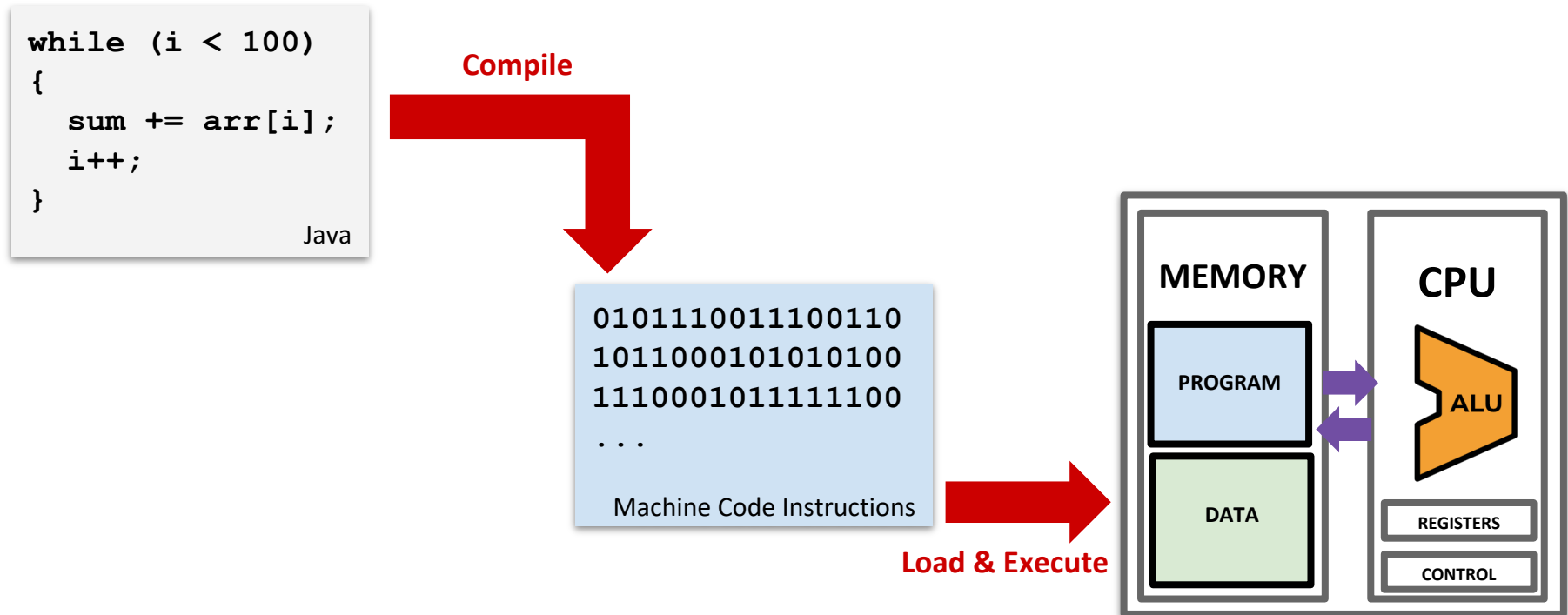

Producing Machine Code

```
while (i < 100)
{
    sum += arr[i];
    i++;
}
```

Java

Compile

```
0101110011100110
1011000101010100
1110001011111100
...
```

Machine Code Instructions

Load & Execute

```
movq $5, %rdx
addq %rsx, %rdx
movq %rdx, %rax
ret
```

Assembly Language

Assemble

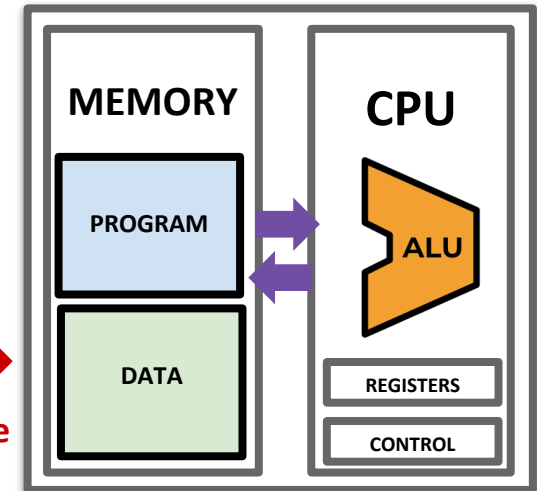

Producing Machine Code

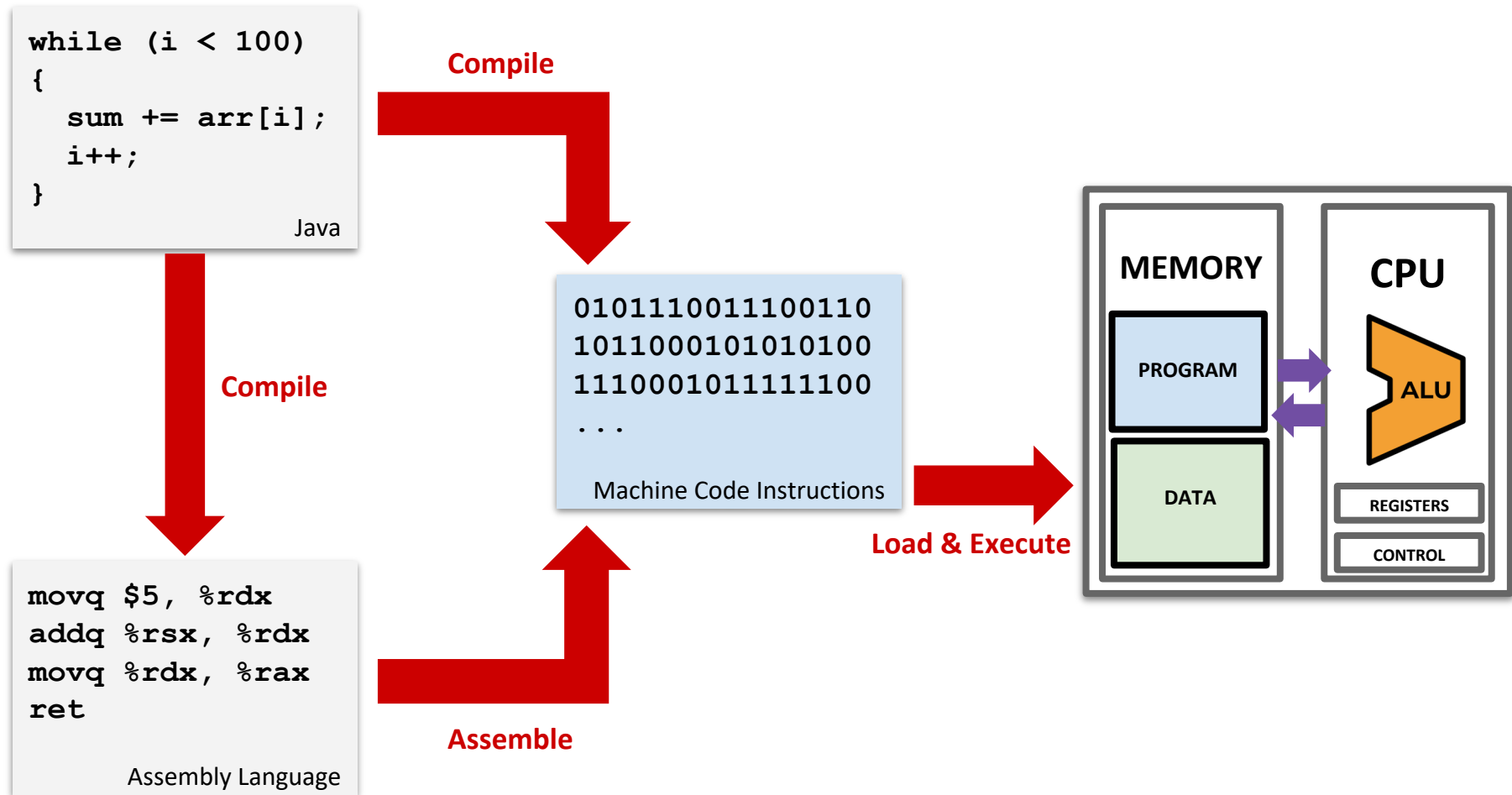

Lecture Outline

- ❖ Annotation Strategies
 - The What and How of Annotating Texts
- ❖ Introduction to Assembly Languages
 - Producing Machine Code
- ❖ **Machine Language Specifications**
 - **Operations, Addressing Modes, & Flow Control**
- ❖ The Hack Assembly Language
 - Registers, A-Instructions, Symbols, & C-Instructions

Machine Language

- ❖ Specification of the Hardware / Software interface
 - What operations are supported?
 - What do they operate on?
 - How is the program controlled?
- ❖ Usually in close correspondence with the hardware architecture
 - Different specification for different hardware platforms
- ❖ Cost and Performance Tradeoffs
 - Silicon area and complexity
 - Time to complete instruction
 - Power consumption

Machine Operations

- ❖ Correspond to the operations supported by hardware:
 - Arithmetic (+, -)
 - Logical (And, Or)
 - Flow Control (“go to instruction n”, “if (condition) then go to instruction n”)

- ❖ Differences between machine languages:
 - Instruction set richness (e.g., division? bulk copy?)
 - Data types (e.g., word size, floating point)

Registers

- ❖ CPU typically has a small number of **registers**
 - Very efficient to access
 - Used for intermediate, short-term “scratch work”
- ❖ Number and use of registers is a central part of any machine language

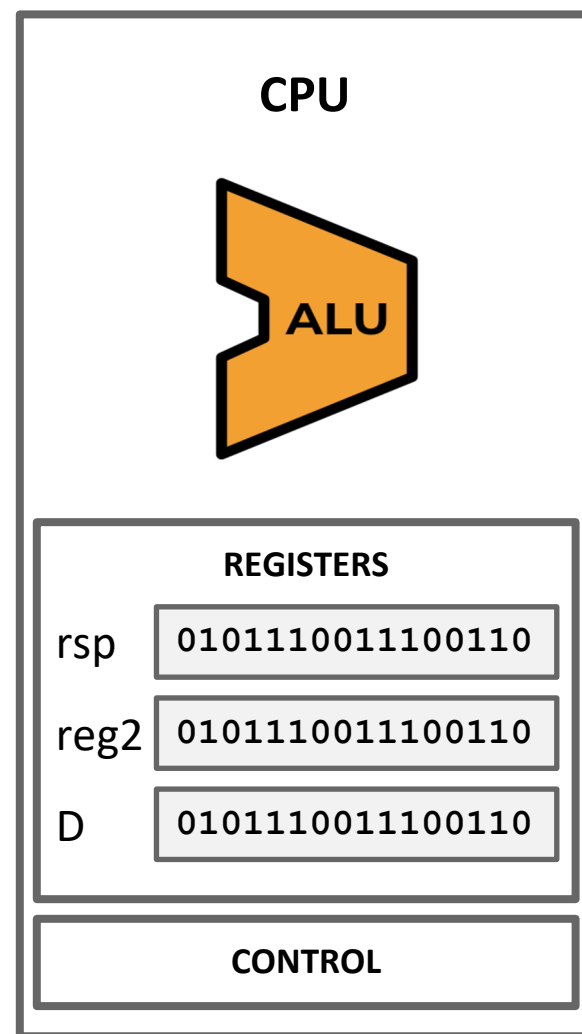

Addressing Modes

❖ Ways to specify operands or inputs in assembly

❖ Some useful options:

▪ Register

• `add reg1, reg2`

Register names



▪ Direct Memory Access

• `add reg1, Memory[200]`

Access the giant array (i.e., memory) at index 200



▪ Indirect Memory Access

• `add reg1, Memory[reg2]`

▪ Immediate

• `add 100, reg2`

Flow Control

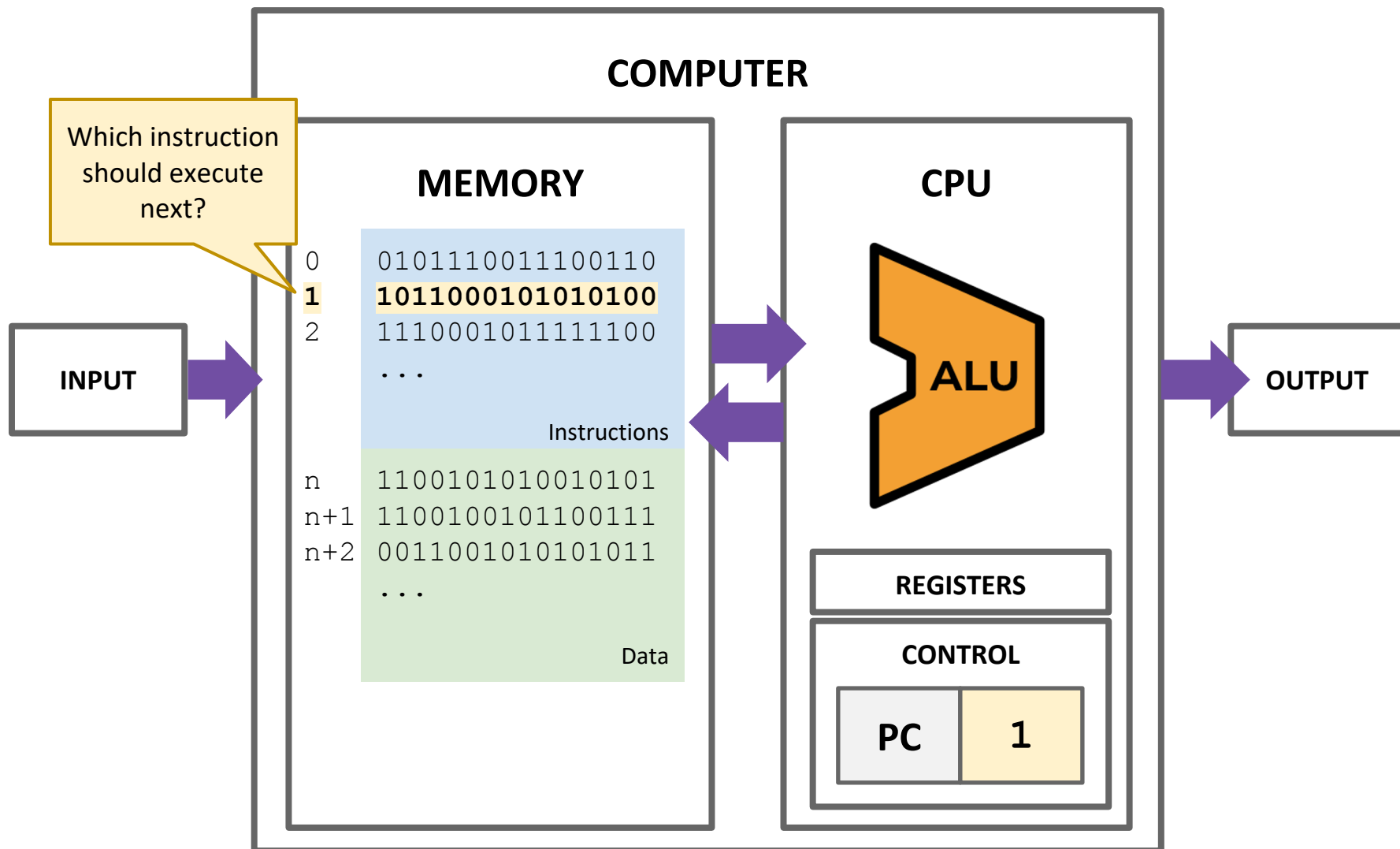

Flow Control

- ❖ Usually, the CPU just executes machine instructions in a sequence
 - Typically moves to the instruction with the next highest address
- ❖ Sometimes we want to **always** “jump” to another location
 - Example: At the end of an infinite loop

High Level Code (similar to Java)	Assembly Code
<pre>while (true) { reg1++; <more loop body> } <code after loop></pre>	<pre>TOP: add 1, reg1 <more loop body> jmp TOP <code after loop></pre>

Flow Control

- ❖ Usually, the CPU just executes machine instructions in a sequence
 - Typically moves to the instruction with the next highest address
- ❖ Sometimes we want to “jump” **only if a condition is met**
 - Example: At the condition of an if statement

High Level Code (similar to Java)	Assembly Code
<pre>if (reg1 < reg2) { reg1++; } reg2++;</pre>	<pre> cmp reg1, reg2 jge SKIP add 1, reg1 SKIP: add 1, reg2</pre>

Five-minute Break!

- ❖ Feel free to stand up, stretch, use the restroom, drink some water, review your notes, or ask questions
- ❖ We'll be back at:
- ❖ Research shows mid-lecture breaks reduce the decline of attention in the middle of lecture (Olmsted, 1999)

Lecture Outline

- ❖ Annotation Strategies
 - The What and How of Annotating Texts
- ❖ Introduction to Assembly Languages
 - Producing Machine Code
- ❖ Machine Language Specifications
 - Operations, Addressing Modes, & Flow Control
- ❖ **The Hack Assembly Language**
 - **Registers, A-Instructions, Symbols, & C-Instructions**

The Hack Computer

- ❖ The hardware you will build
 - 16-bit word size
 - ROM: sequence of instructions
 - `ROM[0]`, `RAM[1]`...
 - RAM: data sequence
 - `RAM[0]`, `RAM[1]`...

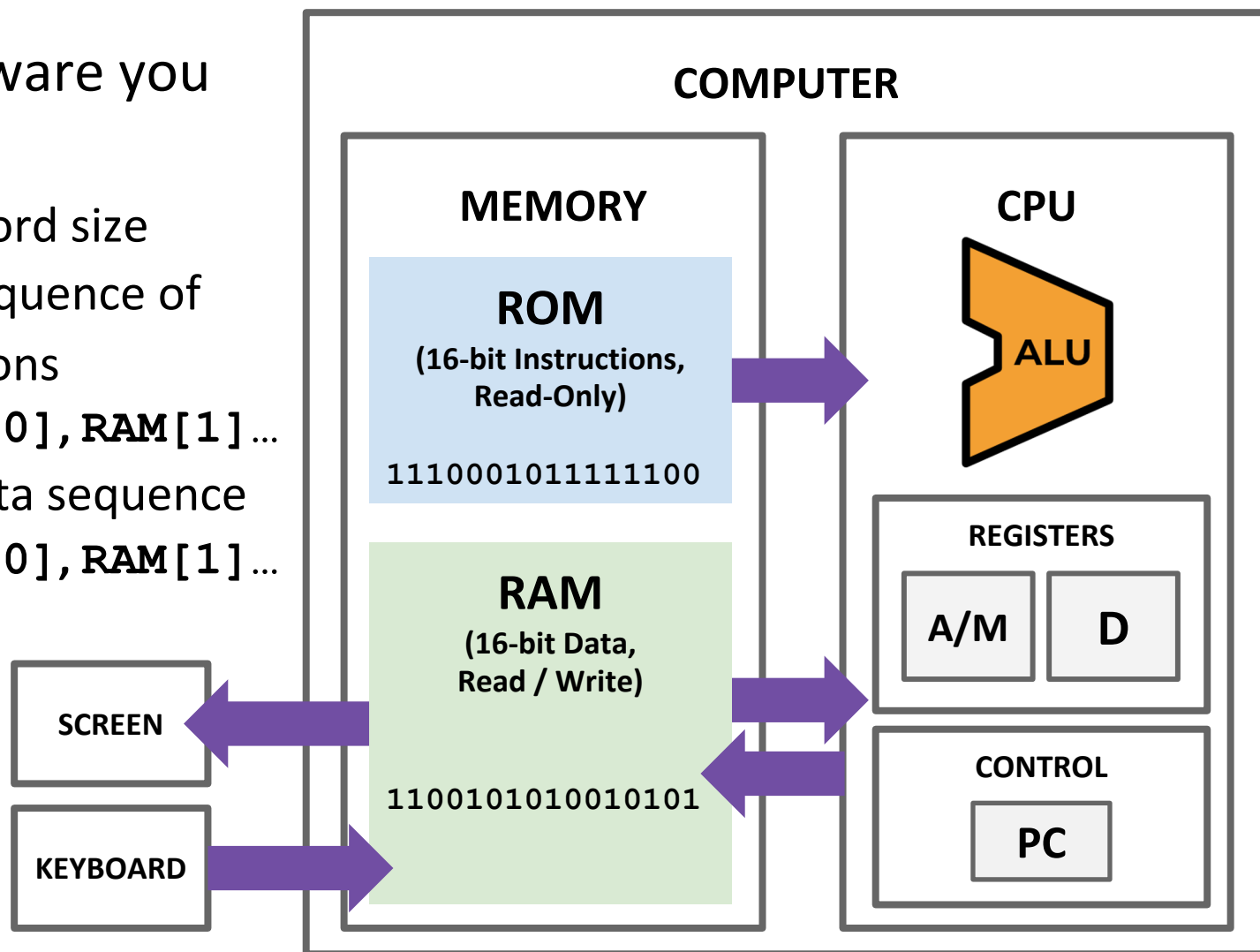

The Hack Machine Language

- ❖ Two types of instructions (16-bit)
 - A-instructions *load data*
 - C-instructions perform *computations*
- ❖ Program: sequence of instructions

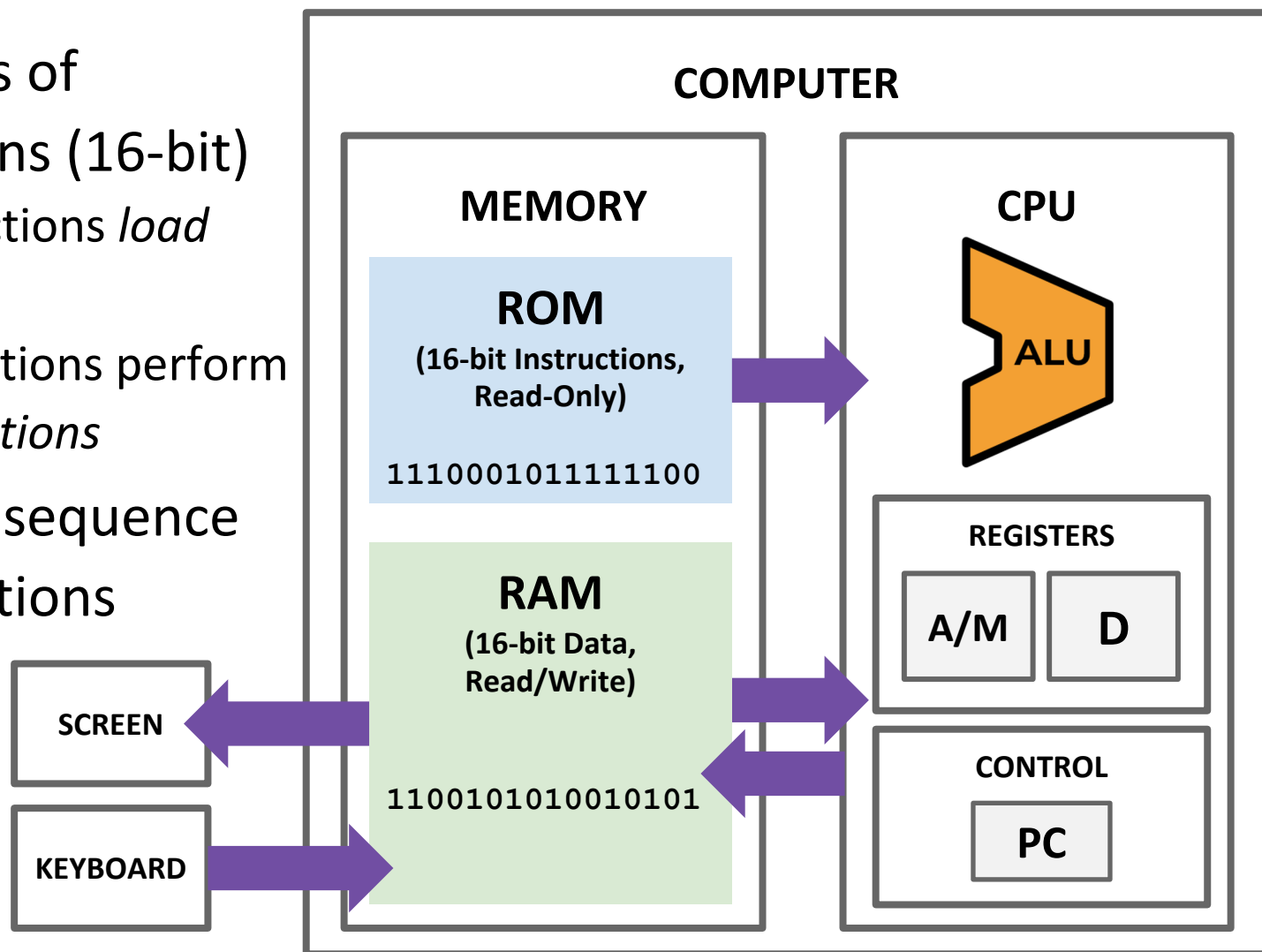

Hack: Control Flow

❖ Startup

- Hack instructions loaded into ROM
- Reset signal initializes computer state (**instruction 0**)

❖ Execution

- Usually, **advance to next** instruction each cycle
- On jump instruction, **write a different address** into the PC

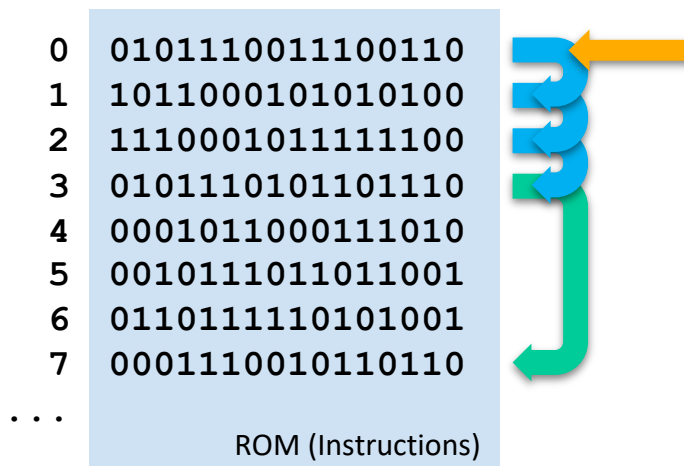

Program Counter (PC)

- ❖ Keeps track of what instruction we are executing
 - If the PC outputs 24, on the next clock cycle the computer runs the instruction at address 24 in the code segment

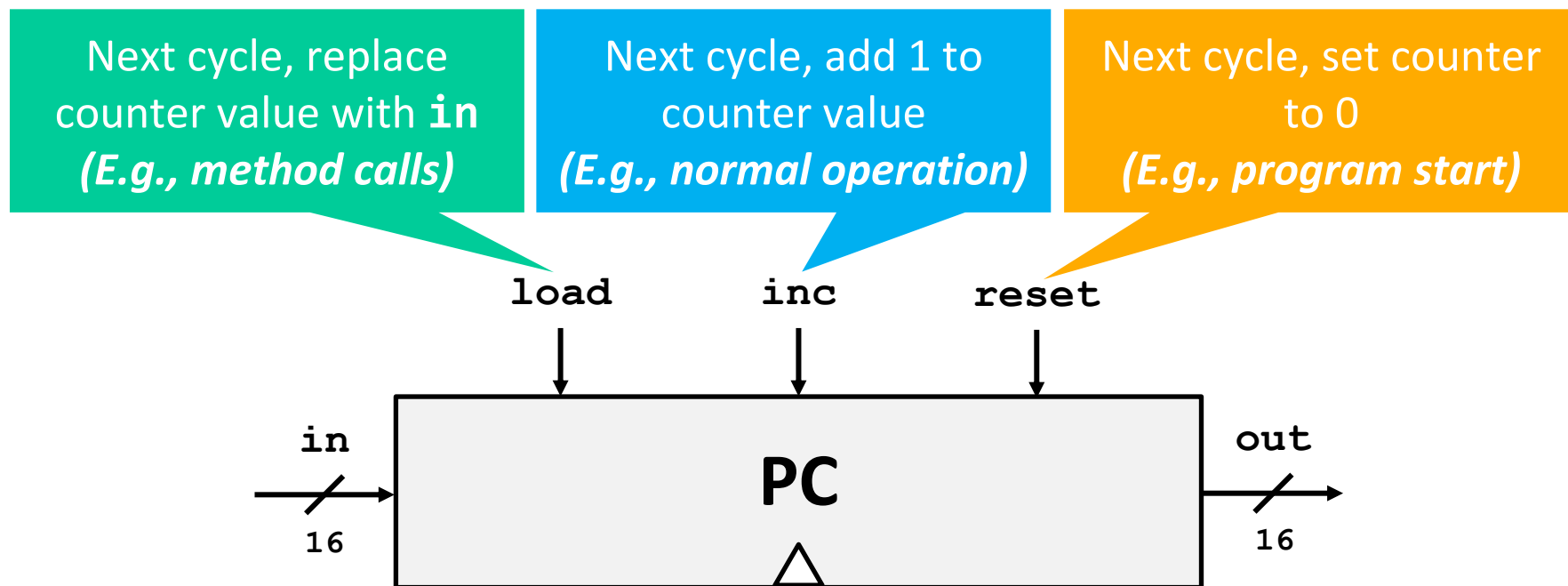

Hack: Registers

- ❖ D Register: For storing Data
- ❖ A Register: For storing data *and* Addressing memory
- ❖ M “Register”: The 16-bit word in Memory currently being referenced by the address in A

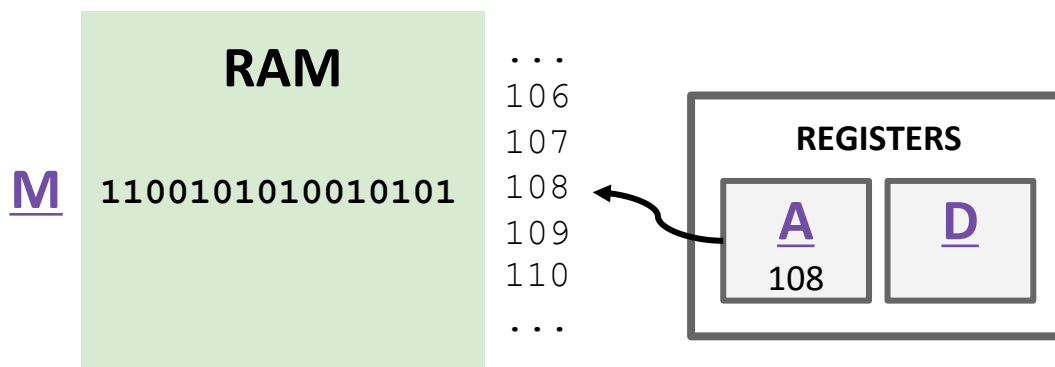

Hack: A-Instructions

- ❖ Syntax: `@value`
- ❖ **value** can either be:
 - A non-negative decimal constant
 - A symbol referring to a constant
- ❖ Semantics:
 - Stores **value** in the A register

Hack: A-Instructions

❖ Symbolic Syntax

@value

- Loads a value into the A register

❖ Binary Syntax

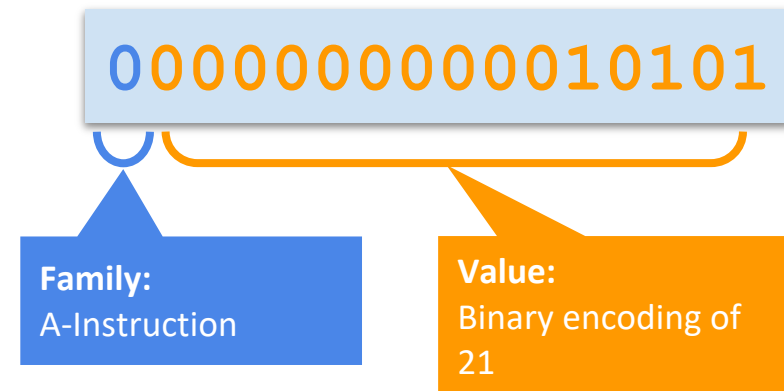

❖ Example:

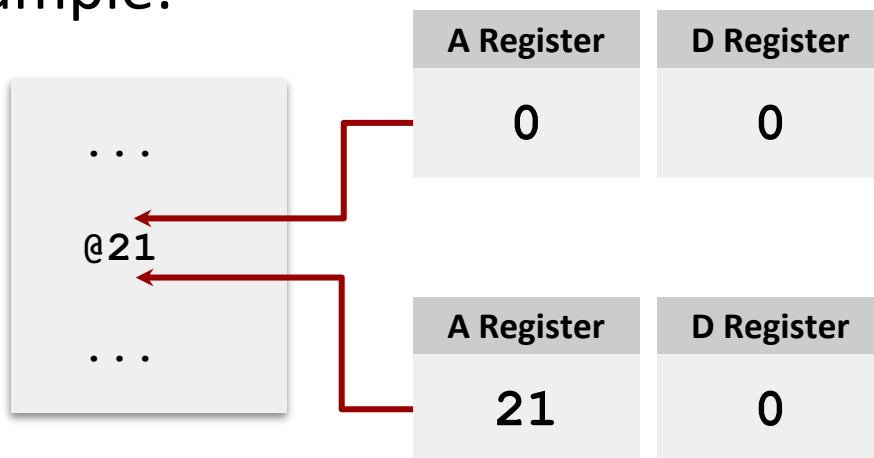

Hack: Symbols

- ❖ Symbols are simply an alias for some address
 - Only in the symbolic code—don't turn into a binary instruction
 - Assembler converts use of that symbol to its value instead

- ❖ Example:

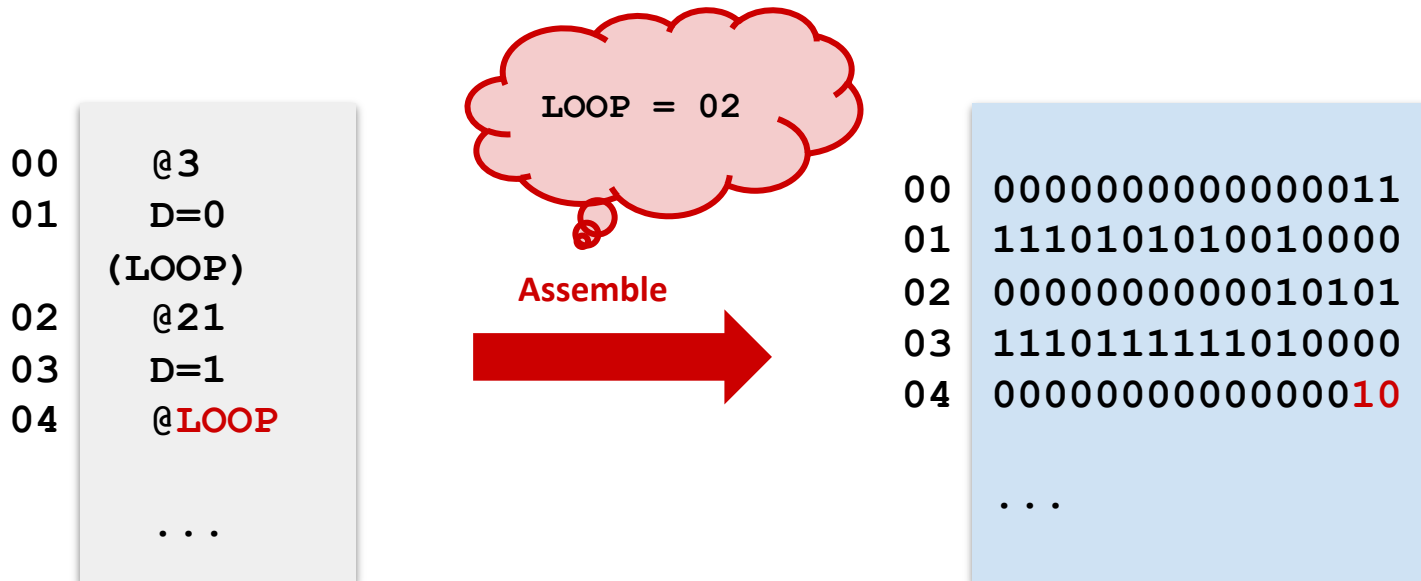

Hack: Built-In Symbols

- ❖ Using () defines a symbol in ROM / Instructions
- ❖ Assembler knows a few built-in symbols in RAM / Data
- ❖ **R0**, **R1**, . . . , **R15**: Correspond to addresses at the very beginning of RAM (0, 1, ..., 15)
 - “Virtual registers,” Useful to store variables
- ❖ **SCREEN**, **KBD**: Base of I/O Memory Maps
- ❖ Example:

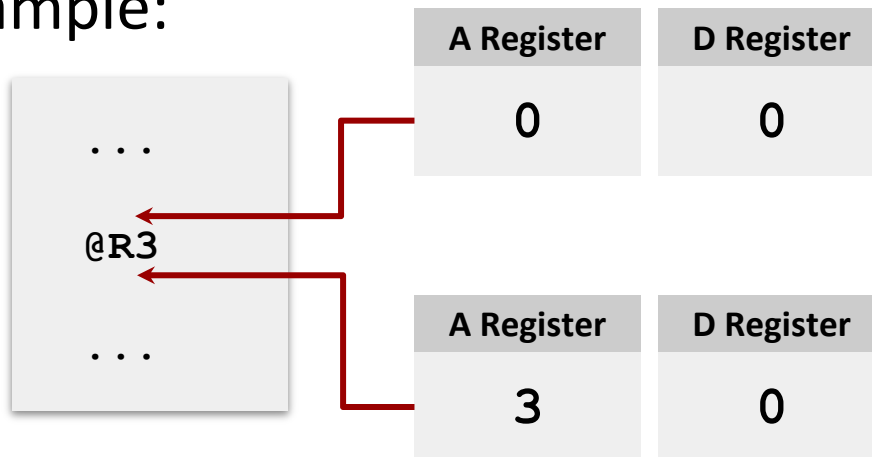

Hack: C-Instructions

❖ Syntax: `dest = comp ; jump` (**dest** and **jump** optional)

- **dest** is a combination of destination registers:

`M, D, MD, A, AM, AD, AMD`

- **comp** is a computation:

`0, 1, -1, D, A, !D, !A, -D, -A, D+1, A+1, D-1, A-1, D+A, D-A, A-D, D&A, D|A, M, !M, -M, M+1, M-1, D+M, D-M, M-D, D&M, D|M`

- **jump** is an unconditional or conditional jump:

`JGT, JEQ, JGE, JLT, JNE, JLE, JMP`

❖ Semantics:

- Computes value of **comp**
- Stores results in **dest** (if specified)
- If **jump** is specified and condition is true (by testing **comp** result), jump to instruction **ROM[A]**

Hack: C-Instructions

❖ Symbolic: `dest = comp ; jump`

❖ Binary: `1 1 1 a c1 c2 c3 c4 c5 c6 d1 d2 d3 j1 j2 j3`

Family:
C-Instruction

Unused

Comp:
ALU Operation (a bit chooses
between A and M)

Dest:
Where to store
result

Jump:
Condition for
jumping

Hack: C-Instructions

❖ Symbolic: `dest = comp ; jump`

❖ Binary: `1 1 1 a c1 c2 c3 c4 c5 c6 d1 d2 d3 j1 j2 j3`

Jump:
Condition for jumping

Chapter 4

j1 (<i>out</i> < 0)	j2 (<i>out</i> = 0)	j3 (<i>out</i> > 0)	Mnemonic	Effect
0	0	0	null	No jump
0	0	1	JGT	If <i>out</i> > 0 jump
0	1	0	JEQ	If <i>out</i> = 0 jump
0	1	1	JGE	If <i>out</i> ≥ 0 jump
1	0	0	JLT	If <i>out</i> < 0 jump
1	0	1	JNE	If <i>out</i> ≠ 0 jump
1	1	0	JLE	If <i>out</i> ≤ 0 jump
1	1	1	JMP	Jump

Hack: C-Instructions

❖ Symbolic: `dest = comp ; jump`

❖ Binary: `1 1 1 a c1 c2 c3 c4 c5 c6 d1 d2 d3 j1 j2 j3`

Dest:
Where to store
result

d1	d2	d3	Mnemonic	Destination (where to store the computed value)
0	0	0	null	The value is not stored anywhere
0	0	1	M	Memory[A] (memory register addressed by A)
0	1	0	D	D register
0	1	1	MD	Memory[A] and D register
1	0	0	A	A register
1	0	1	AM	A register and Memory[A]
1	1	0	AD	A register and D register
1	1	1	AMD	A register, Memory[A], and D register

Chapter 4

Hack: C-Instructions

❖ Symbolic: `dest = comp ; jump`

❖ Binary: `1 1 1 a c1 c2 c3 c4 c5 c6 d1 d2 d3 j1 j2 j3`

(when a=0) <i>comp mnemonic</i>	c1	c2	c3	c4	c5	c6	(when a=1) <i>comp mnemonic</i>
0	1	0	1	0	1	0	
1	1	1	1	1	1	1	
-1	1	1	1	0	1	0	
D	0	0	1	1	0	0	
A	1	1	0	0	0	0	M
!D	0	0	1	1	0	1	
!A	1	1	0	0	0	1	!M
-D	0	0	1	1	1	1	
-A	1	1	0	0	1	1	-M
D+1	0	1	1	1	1	1	
A+1	1	1	0	1	1	1	M+1
D-1	0	0	1	1	1	0	
A-1	1	1	0	0	1	0	M-1
D+A	0	0	0	0	1	0	D+M
D-A	0	1	0	0	1	1	D-M
A-D	0	0	0	1	1	1	M-D
D&A	0	0	0	0	0	0	D&M
D A	0	1	0	1	0	1	D M

Comp:
ALU Operation (a bit chooses between A and M)

Chapter 4

Important: just pattern matching text!
Cannot have "1+M"

Hack: C-Instructions Example

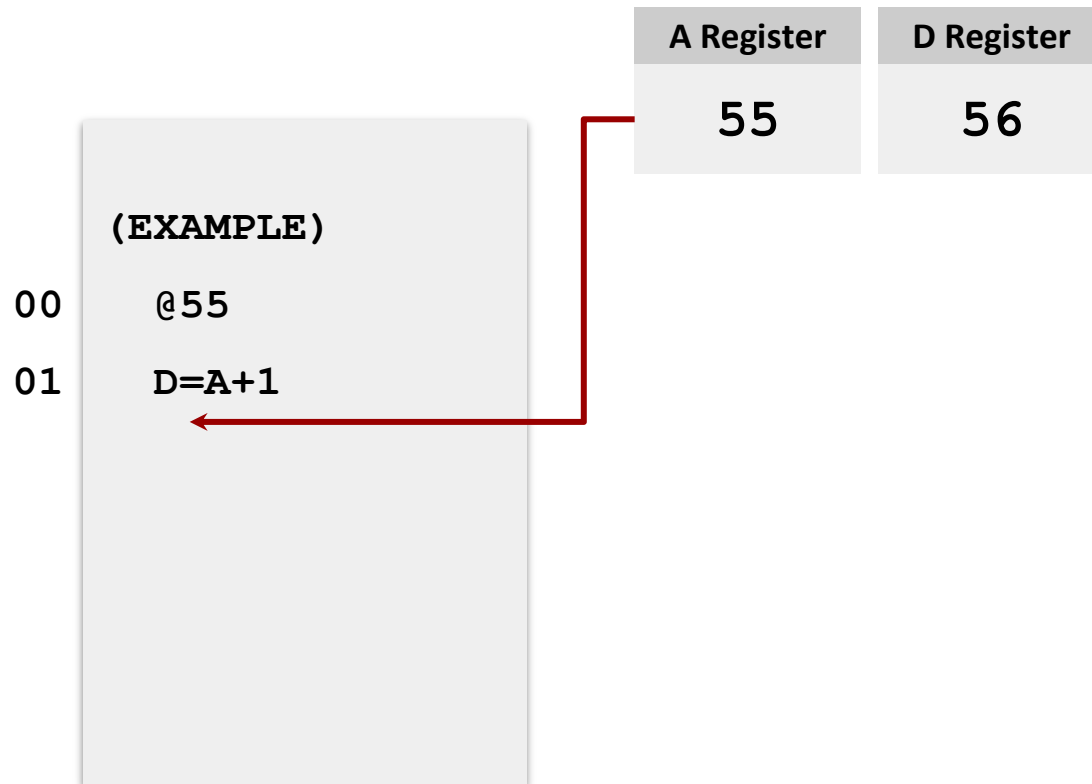

Hack: C-Instructions Example

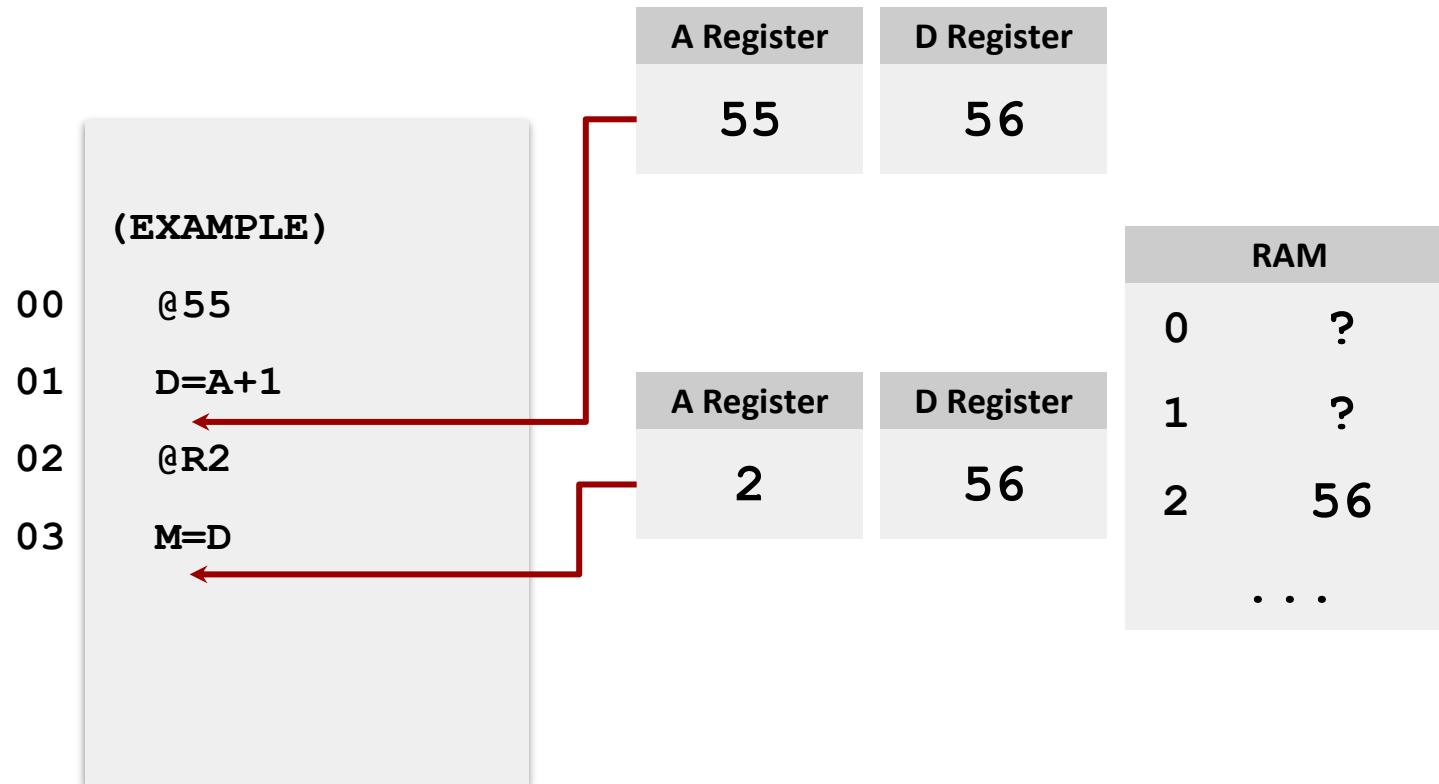

Hack: C-Instructions Example

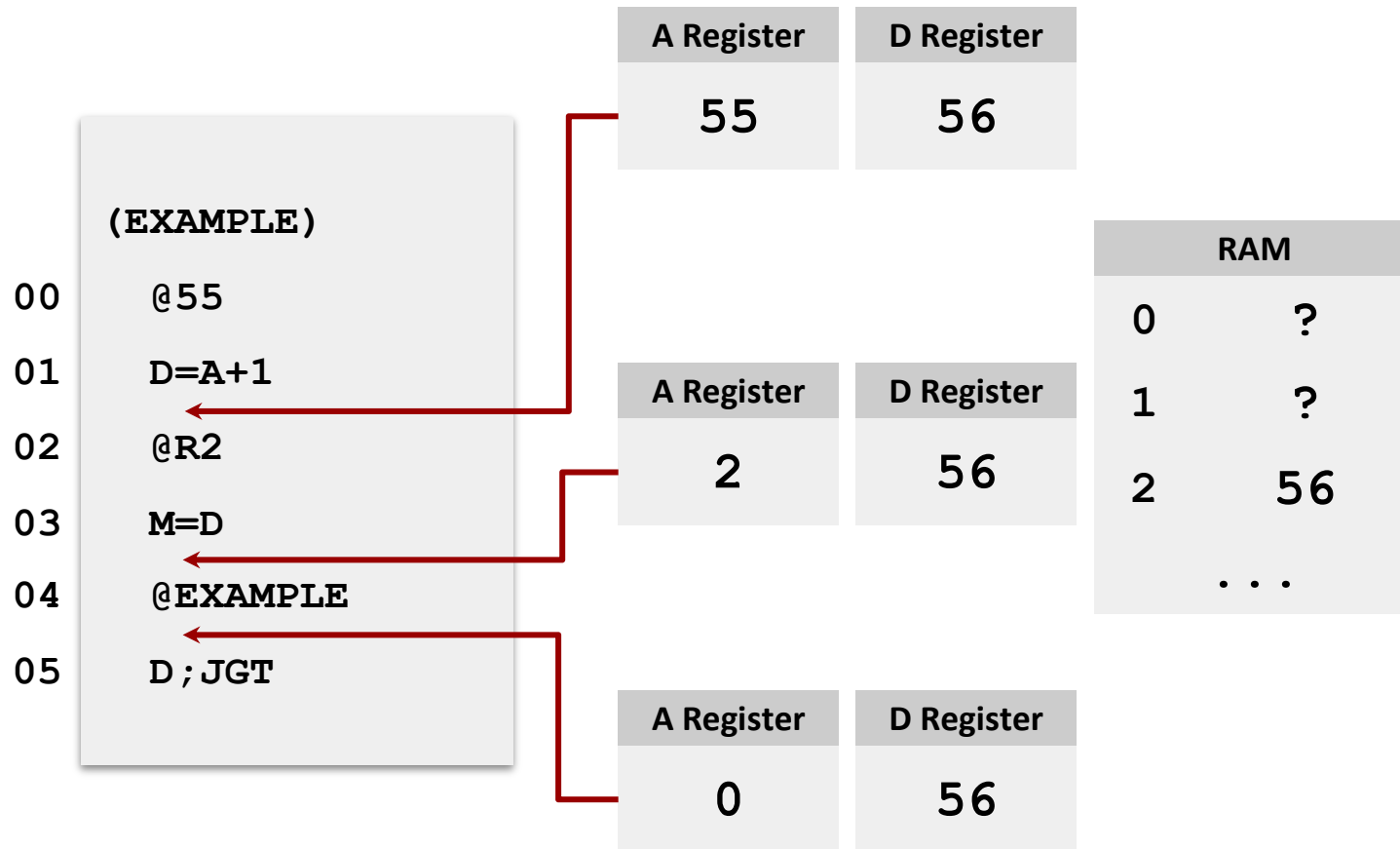

(Will jump to instruction 0, since $D > 0$)

Lecture 7 Wrap-up

- ❖ Project Reminders
 - Project 3 grades released by Thursday (feedback on Gradescope)
 - **Project 4 due Thursday (4/21) at 11:59pm PDT**
- ❖ Project Scores and Late Days are updated weekly and can be viewed on Canvas under “Assignments”
- ❖ Lecture 8 Reading: [Final Memory Chip](#)